

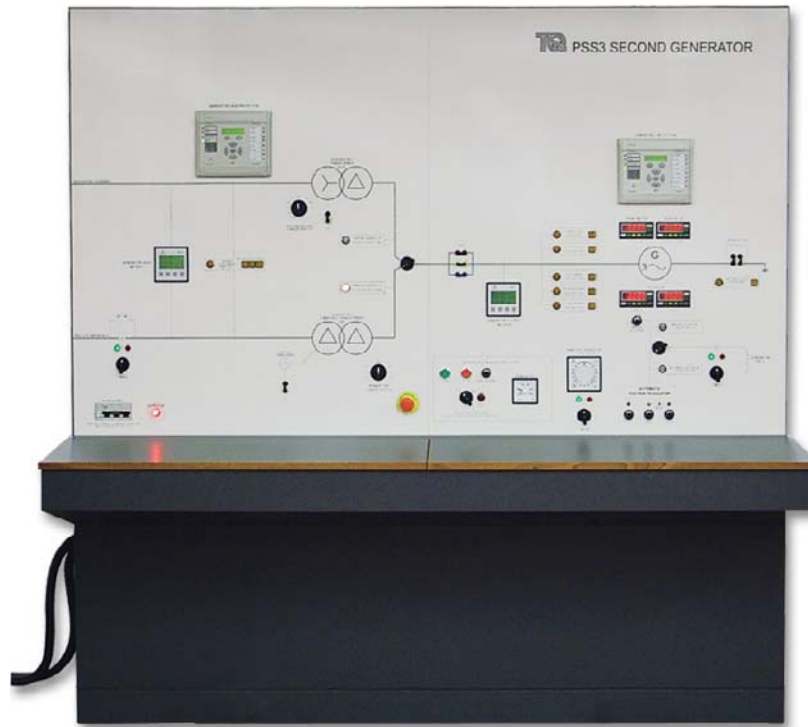

PSS3

SECOND GENERATOR

A self-contained motor and generator set that connects to TecEquipment's Electrical Power System Simulator (PSS1) for extra experiments in central and embedded generation.



KEY FEATURES

- Synchronises with the grid supply and generator of the Electrical Power System Simulator
- Includes distribution and generator transformers
- Includes different generator excitation methods for advanced studies
- Generator earth point has removable link and earthing resistor for generator earth fault and neutral voltage studies

KEY SPECIFICATIONS

- Prime mover and generator
- Two protection relays
- Distribution and generator transformers with variable tapings
- Six digital meters
- Automatic voltage regulator

LEARNING OUTCOMES

- Central and embedded generation
- Synchronising and paralleling with another three-phase source (mains or generator)
- Load sharing and stiff/weak systems
- Circulating current monitoring
- Three-source systems: connecting the generator at the central generation or embedded generation level
- Automatic voltage regulator operation in constant reactive power and constant power factor modes

SECOND GENERATOR

DESCRIPTION

A self-contained motor and generator set that operates as a second generator for TecQuipment's Electrical Power System Simulator (PSS1). It provides extra experiments and studies into power generation.

The motor (prime mover) and generator set consists of two coupled machines mounted in the base of the control console. Manual or different types of automatic excitation control the output of the generator. A vector drive controls the speed of the motor. Digital meters show the conditions of the prime mover and generator.

The relays show students how actual generators are protected and the different ways that they are protected. Students can set the relays from their control panels. The relays also include sockets to link them to a suitable computer (computer not included) for more detailed programming, if needed. The relays operate the circuit-breakers around the second generator. The circuit-breakers also include hand-operated switches, and lamps. The lamps show whether the circuit-breaker is open or closed.

The Second Generator links to the Electrical Power System Simulator at the higher voltage (transmission) level to simulate central generation, for example main power stations.

The Second Generator also links to the Electrical Power System Simulator at the lower voltage (utilisation) level to simulate embedded generation directly to a load, for example a generator at a factory or hospital.

Multifunction digital meters at the generator output and the utilisation and distribution outputs show the conditions of all three phases.

STANDARD FEATURES

- Supplied with comprehensive user guide
- Five-year warranty
- Made in accordance with the latest European Union directives
- ISO9001 certified manufacturer

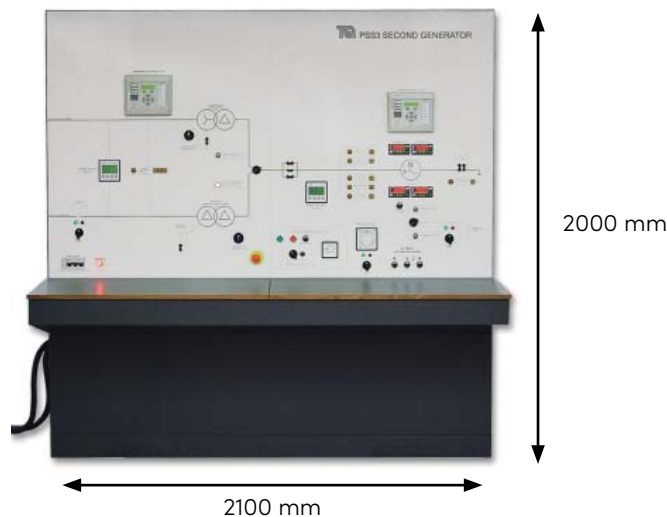
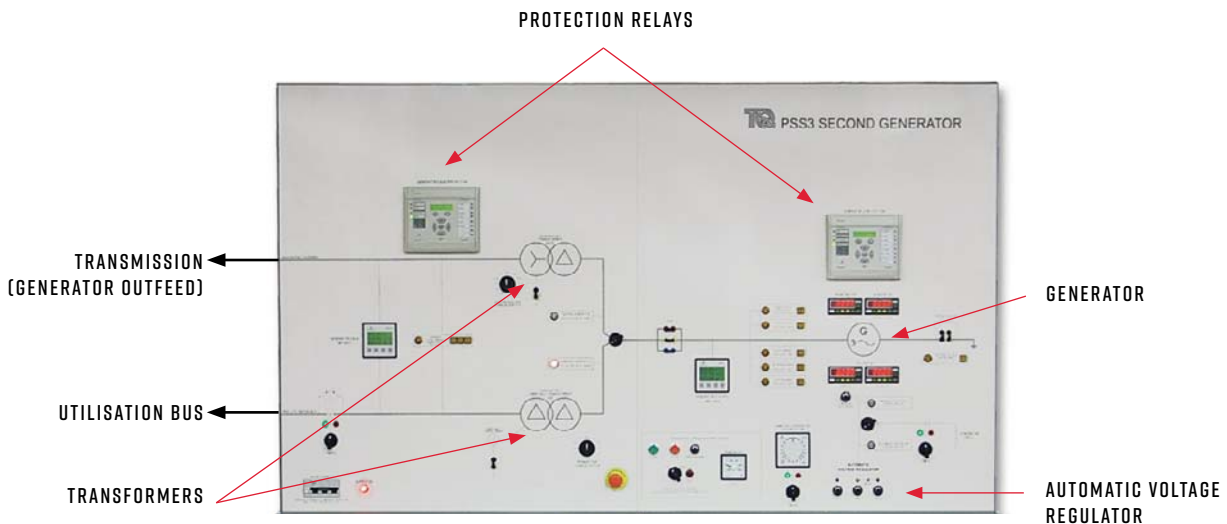

SECOND GENERATOR

TYPICAL WORK ASSIGNMENTS

VARIATION OF ARMATURE CURRENT WITH EXCITATION (VEE CURVES)

This experiment tests the generator performance by measuring the output (armature) current while manually adjusting its field excitation, for fixed output powers of 500 W to 2000 W.

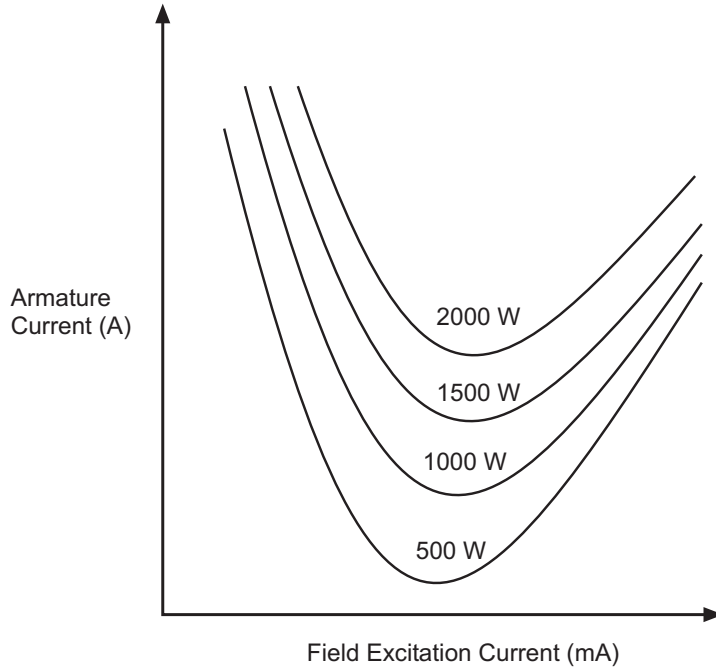

GENERATOR 2 EMBEDDED SUPPLYING A DISTRIBUTION SYSTEM

This experiment synchronises generator 2 to the grid supply and transmission lines of the Electrical Power System Simulator. It shows the differences between real power and reactive power flow in a typical embedded system.

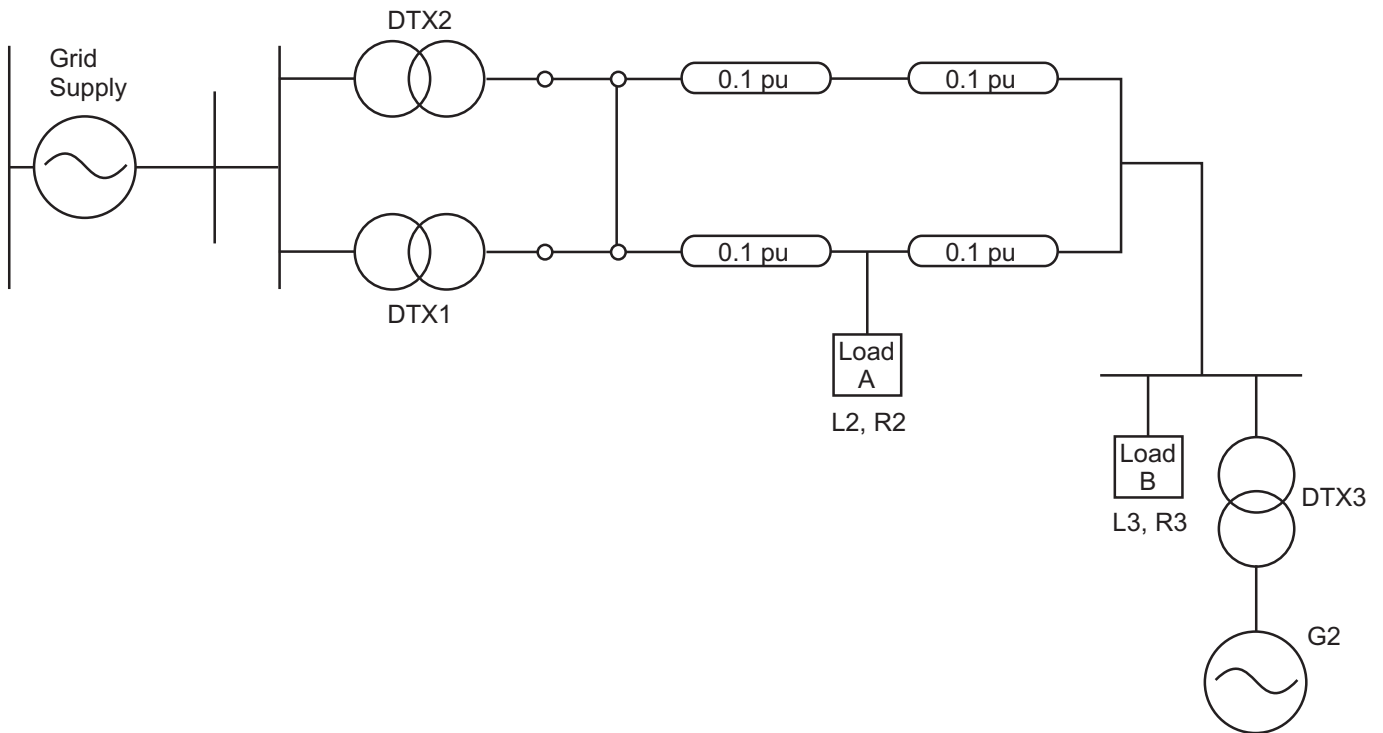

SECOND GENERATOR

DETAILED SPECIFICATIONS

TecQuipment is committed to a programme of continuous improvement; hence we reserve the right to alter the design and product specification without prior notice.

NETT DIMENSIONS AND WEIGHT:

2100 mm long x 2000 mm high x 1500 mm front to back. Allow an extra 500 mm to its left side for power connections, and an extra 1500 mm at the back when access doors are open.

930 kg

APPROXIMATE PACKED VOLUME AND WEIGHT:

5 m³ and 1500 kg

GENERATOR AND MOTOR:

- 6 kVA maximum (operated at a nominal 2 kVA), four-pole salient pole a.c generator. Brushless, with automatic and manual excitation.
- 7 kVA maximum induction motor with shaft encoder and electronic four-quadrant a.c vector drive control.

RELAYS:

- Generator bus protection: overcurrent and earth fault
- Generator protection: over speed and under speed, overvoltage and overcurrent, and loss of mains (from rate of change of frequency and voltage vector shift)

METERS:

- 2 x multi-function meters to show voltage, current and power
- 4 x digital meters to show generator excitation voltage and current, prime mover speed and generator load angle

DISTRIBUTION TRANSFORMER:

- 220 V to 110 V delta-to-delta (Dd0) with adjustable primary tapings and an earthing transformer to the secondary windings

GENERATOR TRANSFORMER:

- 220 V to 220 V delta-to-star (Dy11) with adjustable secondary tapping and an earth link for the secondary star point

ESSENTIAL SERVICES

ELECTRICAL SUPPLY:

Powered from the Electrical Power System Simulator (PSS1)

FLOOR SPACE NEEDED:

Approximately 3 m x 3 m of solid, level floor, located within 4 m of the right-hand end of the Electrical Power System Simulator

OPERATING CONDITIONS

OPERATING ENVIRONMENT:

Laboratory

STORAGE TEMPERATURE RANGE:

-25°C to +55°C (when packed for transport)

OPERATING TEMPERATURE RANGE:

+5°C to +40°C

OPERATING RELATIVE HUMIDITY RANGE:

80% at temperatures < 31°C decreasing linearly to 50% at 40°C

SOUND LEVELS

Less than 70 dB(A)